

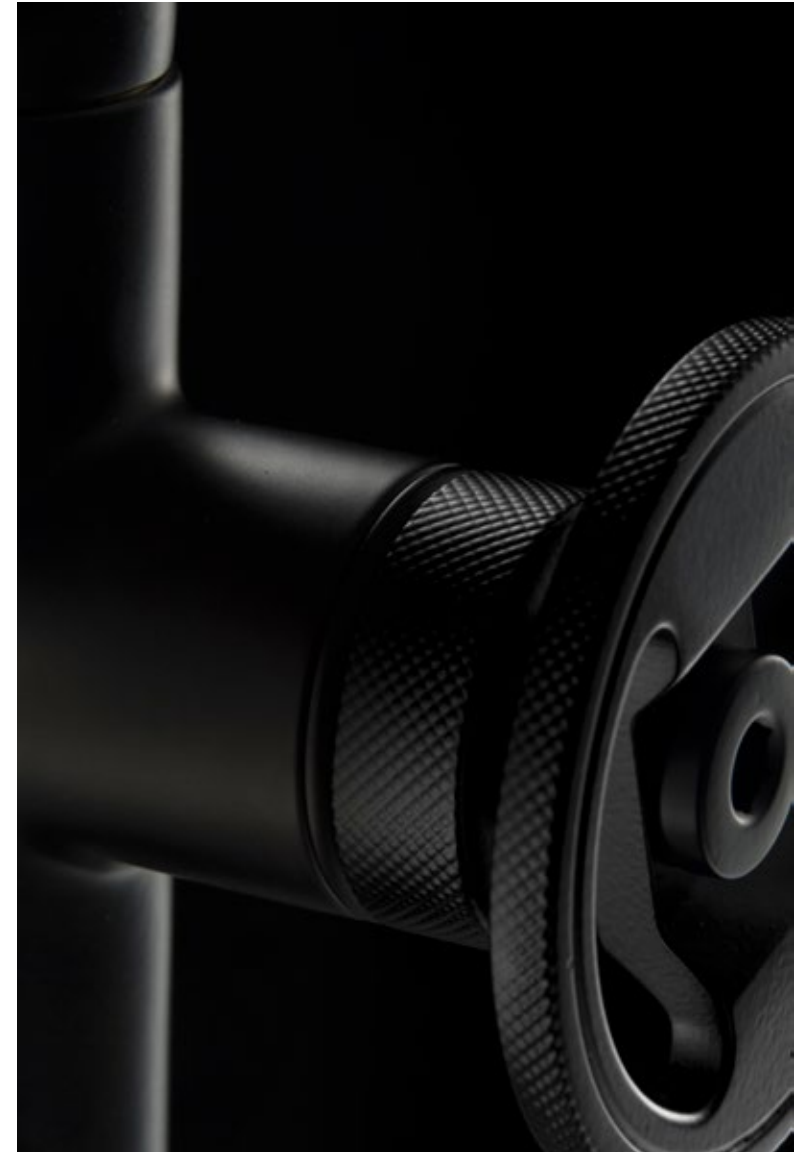

IB RUBINETTI

**BOLD
BATHROOM
COLLECTION**

Design
Federico Castelli + Antonio Gardoni



WE ARE ITALIAN DESIGN CULTURE

ITA

IB RUBINETTI nasce nel 1985 da un'idea e dalla passione di elio bregoli fondatore e presidente dell'azienda. IB RUBINETTI scrive la sua storia su delle basi solide come la passione per il saper fare, l'amore per il design e la volontà di esportare la cultura italiana. Trent'anni dopo IB RUBINETTI porta questi valori ed i propri prodotti in sessantaquattro paesi nel mondo e sempre più rappresenta uno degli ambasciatori italiani del design.

FRA

IB RUBINETTI was born in the year 1985 from the idea and the passion of Elio Bregoli, founder and President of the company. IB RUBINETTI founds its history on solid basis like the know-how's passion, the love for the good design and the will to export the Italian culture. Thirty years later IB RUBINETTI still believes in these values and exports them in sixty-four countries around the world, establishing itself more and more as one of the ambassadors of the Italian design culture.

ENG

IB RUBINETTI est né en 1985 d'une idée et de la passion de Elio Bregoli, fondateur et Président de la société. IB RUBINETTI écrit son histoire sur une base solide comme une passion pour la qualité, l'amour pour la conception et la volonté d'exporter la culture italienne. Trente ans plus tard, IB RUBINETTI apporte ces valeurs et ses produits dans soixante-quatre pays dans le monde et de plus en plus est l'un des ambassadeurs du design italien.

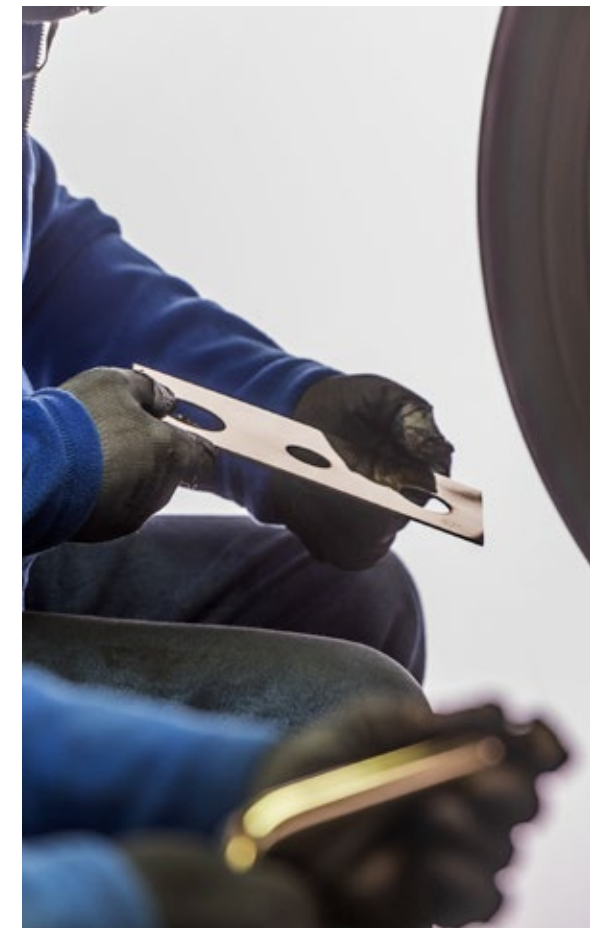

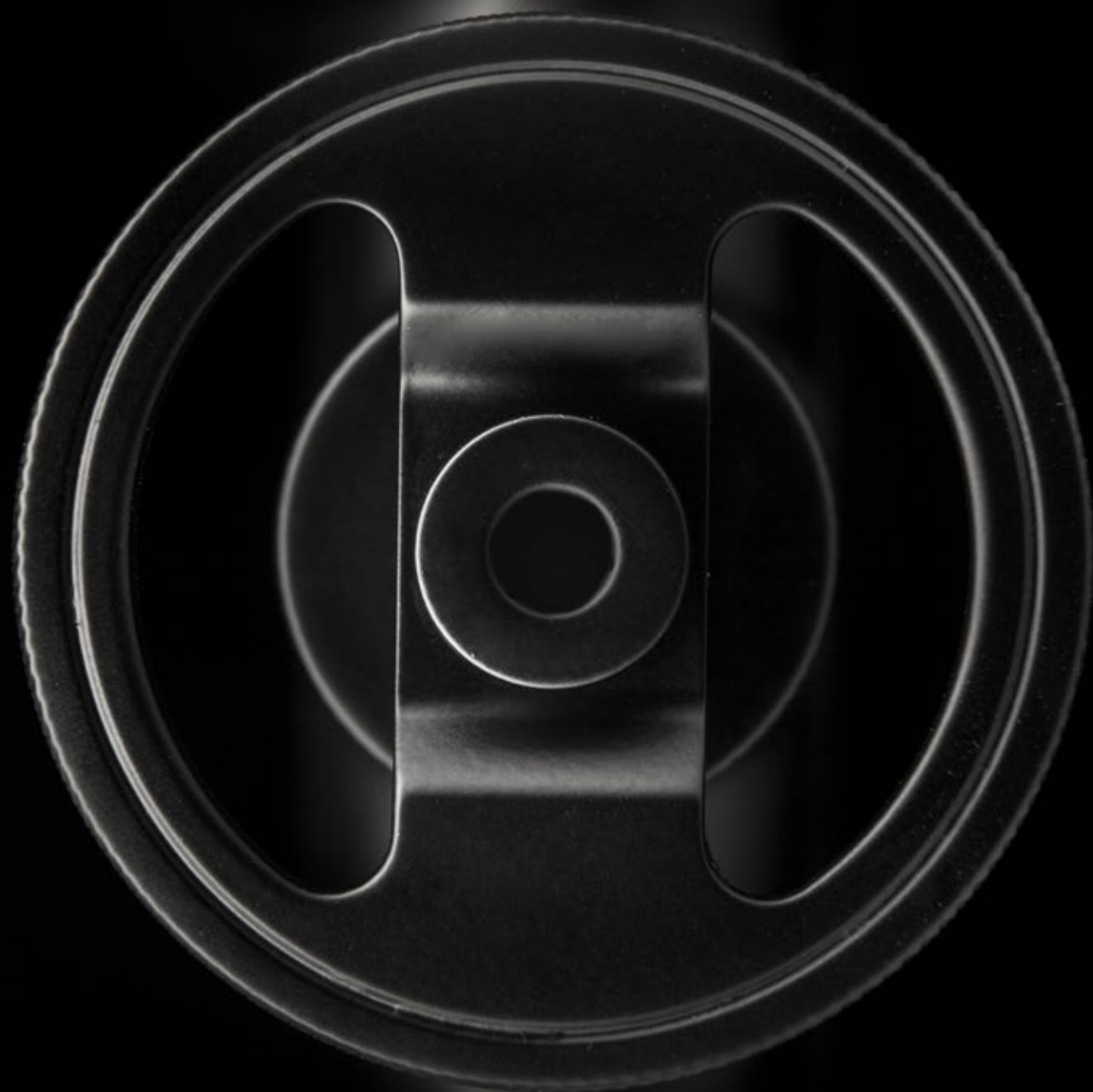

LA COLLEZIONE

L'essenza del rubinetto industriale è nel design di BOLD, la nuova collezione disegnata da Federico Castelli & Antonio Gardoni. Contrassegnati da una zigrinatura che rende facile e agevole la presa, il nome rafforza la particolarità di questi rubinetti che prendono spunto dal design del rubinetto a sfera metropolitano, dove gli aspetti salienti sono la robustezza, l'essenzialità e funzionalità del movimento. Una collezione "di carattere", sintesi di un concept che si rifà all'estetica della leva, con la capacità di creare qualcosa di nuovo nel panorama del design del bagno. BOLD è disponibile con due tipologie di leve – quella "a leva" e "a volantino" – che si combinano a una collezione di prodotti. Un progetto che reinventa un design memorabile proponendosi con audacia nel design contemporaneo e lasciando il segno con un'idea fresca, coraggiosa e non ordinaria. "We are called to be BOLD".

THE COLLECTION

The industrial tap design essence is in the design of the BOLD Collection, the new product designed by Federico Castelli & Antonio Gardoni. Marked with a knurling that makes the grip easy and comfortable, the name reinforces the peculiarity of these taps, inspired by the metropolitan design of the industrial taps, where the salient aspects are robustness, essentiality and functionality. A strong collection, with "character", a synthesis of a concept that focuses on the aesthetics of the lever, with the will to create something new in the landscape of the bathroom design. BOLD is available with two types of levers - the "lever" and the "handwheel" - combined on a collection of products. A project that reinvents a memorable design with a contemporary touch and leaving the mark with a fresh, courageous and unusual idea. "We are called to be BOLD".

LA COLLECTION

L'essence du robinet industriel est dans la conception de BOLD, la nouvelle collection conçue par Federico Castelli et Antonio Gardoni. Marqué avec un quadrillage qui rend la poignée accessible et facile, le nom renforce la particularité de ces robinets, inspiré par le design du robinet à boisseau sphérique métropolitain, où les aspects les plus importants sont la robustesse, l'essentialité et la fonctionnalité du mouvement. Une collection de "personnage", une synthèse d'un concept qui met l'accent sur l'esthétique du levier, avec la capacité de créer quelque chose de nouveau dans le paysage de la conception de la salle de bains. BOLD est disponible avec deux types de leviers : le "levier" et le "manivelle" - qui se combinent avec une collection de produits. Un projet qui réinvente un design mémorable en se proposant audacieusement dans le design contemporain et laissant la marque avec une idée fraîche, courageuse et inhabituelle. "We are called to be BOLD".

The **BOLD** collection is the perfect combination of elemental elements reinterpreted in a contemporary way to suit a large spectrum of bathroom styles and a precise clear statement about water control.

BOLD è la perfetta combinazione di elementi semplici reinterpretati in chiave contemporanea, con un'esplicita estetica funzionale è capace di adattarsi ad ogni stile di bagno.

BOLD est la combinaison parfaite d'éléments simples réinterprétés dans une touche contemporaine. Avec une esthétique fonctionnelle distinctive elle peut s'adapter à tous les styles de salle de bain.

KB2200 CF

Miscelatore lavabo in black chrome spazzolato
Brushed black chrome washbasin mixer
Mitigeur lavabo en black chrome brossé



Marked with a
special knurl
that makes the
grip comfortable,
BOLD is available
with two types of
lever.

BOLD è disponibile con due tipi
di leva. Entrambe contrassegnate
da una speciale zigrinatura che
rende confortevole la presa.

BOLD est disponible avec deux
types de levier. Les deux sont
marqués d'un quadrillage spécial
qui rend la poignée confortable.



KB1
LEVA TONDA
ROUND LEVER
LEVIER ROND

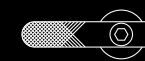
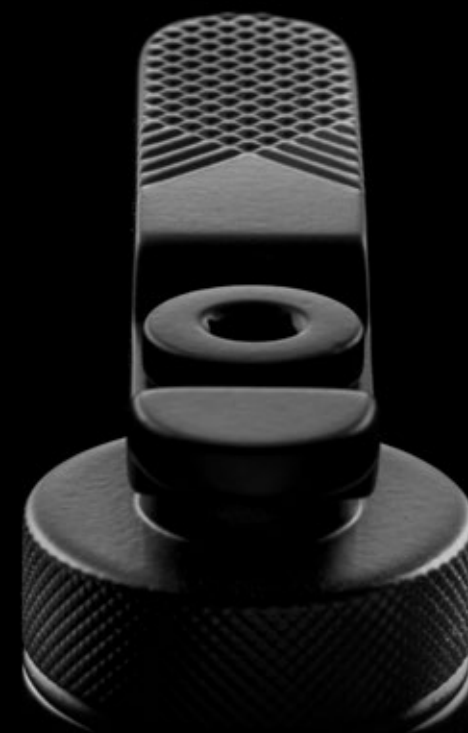

KB2
LEVA PIATTA
FLAT LEVER
LEVIER PLAT

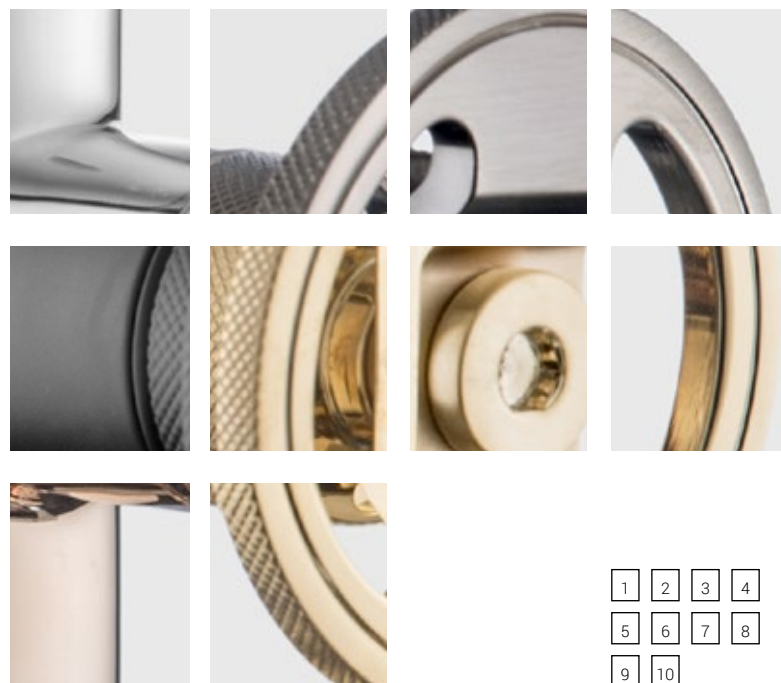

FINITURE / FINISHES / FINITIONS

- 1 CC Cromo / Chrome / Chrome
- 2 CF Black Chrome
- 3 CS Black Chrome Spazzolato / Brushed Black Chrome / Chrome noir brossé
- 4 SS Nickel Spazzolato / Brushed Nickel / Nickel Brossé
- 5 NP Nero Opaco / Matt Black / Noir Mat
- * 6 ON Ottone Naturale / Natural Brass / Laiton naturel
- 7 IS Oro Inglese Spazzolato / Brushed Pale Gold / Or pâle brossé
- 8 II Oro Inglese / Pale Gold / Or pâle
- 9 RS Oro Rosa / Rose Gold / Or Rose
- 10 OO Oro / Gold / Or

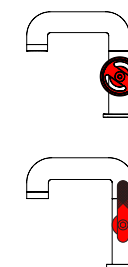

E' possibile avere la leva rossa su qualsiasi delle dieci finiture disponibili.
It is possible to have the red lever on any of the ten finishes available.
Il est possible d'avoir le levier rouge sur toutes les dix finitions disponibles

- * Per sua natura l'ottone naturale nel tempo può variare di colore. Agenti come l'aria, l'acqua, il sapone, ecc cambieranno l'aspetto superficiale rendendo ogni prodotto IB Rubinetti unico e irripetibile.
Over time and by its very nature, natural brass will react and change color as it is exposed to air, water, soaps, etc. creating a patina and providing a truly unique look to your iB Rubinetti fixture.
Pour sa nature le laiton naturelle peut changer de couleur dans le temps. Des agents comme l'air, l'eau, le savon etc changeront l'aspect superficiel de chaque produit iB en le rendant unique et inimitable.

Tutti i nostri prodotti sono pensati e realizzati pensando alla tua salute
All our products are designed and manufactured thinking about your health
Tous nos produits sont conçus et fabriqués en pensant à votre santé





BOLD ROUND + **BOLD FLAT**
KB1200 **KB2200**
 Miscelatore Lavabo Miscelatore Lavabo
 Washbasin mixer Washbasin mixer
 Mitigeur pour lavabo Mitigeur pour lavabo





KB1200 0010,2
Miscelatore Lavabo
Washbasin mixer
Mitigeur pour lavabo



KB1202 0010,9
Lavabo Alto
Tall Washbasin
Mitigeur Haut pour lavabo



KB1205 0012,9
Lavabo monoforo con due leve
Traditional monohole washbasin
with two levers.
Lavabo monotrou avec deux leviers.



KB1220 0010,2
Bidet
Bidet mixer
Mitigeur bidet



KB1209 0012,3
Lavabo a parete monoforo
Monohole built-in basin mixer
Mitigeur lavabo encastré



KB1306 0012,9
Lavabo Incasso tre fori
Three hole built-in washbasin
3 trous mitigeur lavabo Encastré



KB1390 0016,0
Lavabo Tre fori Bocca Alta
Three holes washbasin with Tall Spout
Lavabo 3 trous avec bec long



KB1392 0014,8
Lavabo tre fori Bocca Bassa
Three holes washbasin with Short Spout
Lavabo 3 trous avec bec court



KB1393 0016,0
Bidet 3 fori (Bocca erogazione esterna)
Three Hole Bidet
3 trous bidet



KB1370 0011,7
Lavabo da cucina
Kitchen tall Washbasin
Évier de cuisine



KB1396 0024,4
Bordo vasca 5 Fori
Five hole deck-mounted bath filler
5 trous baignoire



KB1397 0019,5
Bordo vasca 4 fori con uscita per
colonna riempimento
Four hole deck-mounted bath filler
with overflow outlet connection
4 trous baignoire avec remplissage
par trop plein



KB1398 0024,4
Bordo vasca a parete 5 fori
Five hole wall-mounted bath filler
5 trous baignoire mural



KB1400 0007,4
Doccia incasso due fori \ rubinetti arresto
Traditional Built-in shower \ Stopcocks
Robinetterie encastrée douche



KB1410 0012,5
Doccia Incasso Due Vie Tre Fori
Traditional Built-in shower with Two
way diverter
Douche encastrée avec inverseur

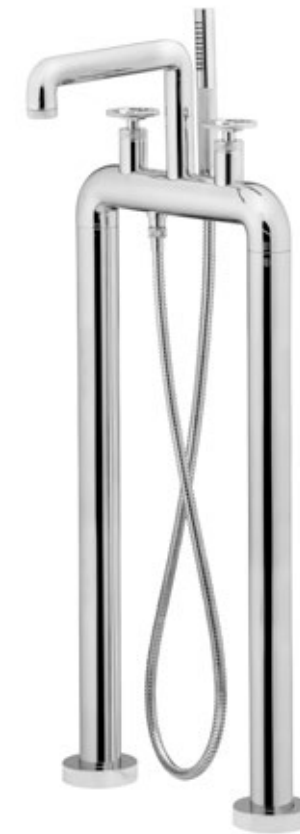

KB1399 0044,3
Bordo vasca da terra
Free-standing Bath Filler mixer
Mitigeur baignoire Free-standing

FINITURE / FINISHES /
FINITIONS

CC	Cromo Chrome Chrome	1
SS	Nickel Spazzolato Brushed Nickel Nickel Brossé	1,5
CF	Black Crome	1,5
CS	Black Crome Spazzolato Brushed Black Crome Black Crome Brossé	1,8
NP	Nero Opaco Matt Black Noir Mat	1,2
OO	Oro Gold Or	1,5
RS	Oro Rosa Rose Gold Or Rose	1,5
II	Oro Inglese Pale Gold Or Pâle	1,5
IS	Oro Inglese Spazzolato Brushed Pale Gold Or Pâle Brossé	1,8
ON	Ottone Naturale Natural Brass Laiton Naturel	1

Leva rossa
Red lever
Levier rouge

-6

+0,1

Per ogni leva montata
sul prodotto
For each lever mounted
on the product
Pour chaque levier
monté sur le produit

+0,1



+0,1





KB2200 0010,2
Miscelatore Lavabo
Washbasin mixer
Mitigeur pour lavabo



KB2202 0010,9
Lavabo Alto
Tall Washbasin
Mitigeur Haut pour lavabo



KB2205 0012,9
Lavabo monoforo con due leve
Traditional monohole washbasin
with two levers
Lavabo monotrou avec deux leviers



KB2220 0010,2
Bidet
Bidet mixer
Mitigeur bidet



KB2209 0012,3
Lavabo a parete monoforo
Monohole built-in basin mixer
Mitigeur lavabo encastré



KB2306 0012,9
Lavabo Incasso tre fori
Three hole built-in washbasin
3 trous mitigeur lavabo Encastré



KB2206 0010,8
Lavabo Incasso
Built-in washbasin
Mitigeur lavabo Encastré



KB2320 0003,8
Bocca d'erogazione
Spout
Bec



KB2390 0016,0
Lavabo Tre fori Bocca Alta
Three holes washbasin with Tall Spout
Lavabo 3 trous avec bec long



KB2392 0014,8
Lavabo tre fori Bocca Bassa
Three holes washbasin with Short Spout
Lavabo 3 trous avec bec court



KB2393 0016,0
Bidet 3 fori (Bocca erogazione esterna)
Three Hole Bidet
3 trous bidet



KB2210 0024,6
Lavabo da soffitto
Ceiling Washbasin mixer
Mitigeur Lavabo avec bec Plafond

Disponibile / Available / Disponible

Cromo / Chrome / Chrome

Nickel Spazzolato / Brushed Nickel /
Nickel Brossé

Ottone Naturale / Natural Brass /
Laiton Naturel



KB2300 0006,9
Doccia Incasso
Built-in shower
Mitigeur douche encastré



KB2305 0004,8
Doccia Incasso
Built-in shower
Mitigeur douche encastré



KB2313 0014,5
Doccia incasso due vie con doccetta
Two ways built-in shower with hand shower
Mitigeur douche encastré 2 sorties
avec douchette à main



KB2310 0008,8
Doccia Incasso Due Vie
Two Ways Built-in shower
Mitigeur douche encastré 2 sorties



KB2312 0010,8
Doccia Incasso Tre Vie
Three Ways Built-in shower
Mitigeur douche encastré 3 sorties



KB2314 0016,8
Doccia incasso tre vie con doccetta
Three Ways Built-in shower with hand shower
Mitigeur douche encastré 3 sorties
avec douchette à main



KB2370 0011,7
Lavabo da cucina
Kitchen tall Washbasin
Évier de cuisine



KB2396 0024,4
Bordo vasca 5 Fori
Five hole deck-mounted bath filler
5 trous baignoire



KB2397 0019,5
Bordo vasca 4 fori con uscita per
colonna riempimento
Four hole deck-mounted bath filler
with overflow outlet connection
4 trous baignoire avec remplissage
par trop plein



KB2398 0024,4
Bordo vasca a parete 5 fori
Five hole wall-mounted bath filler
5 trous baignoire mural



KB2400 0007,4
Doccia incasso due fori \ rubinetti arresto
Traditional Built-in shower \ Stopcocks
Robinetterie encastrée douche



KB2410 0012,5
Doccia Incasso Due Vie Tre Fori
Traditional Built-in shower with Two
way diverter
Douche encastrée avec inverseur



KB2399 0044,3
Bordo vasca da terra
Free-standing Bath Filler mixer
Mitigeur baignoire Free-standing



KB2022 0005,2
Duplex Tondo
Round duplex
Duplex rond



↔ 422CCXN_B1
↑ 412CCXN_B1 0029,8
Kit maniglie Bold per sistema termo-
statico Euphoria o Blaze quattro vie
Bold valve handles trim kit for
euphoria and blaze thermostatic
shower unit four ways
Poignées Bold pour système
thermostatique Euphoria ou Blaze -
quatre voies



KB2800 0048,8
Colonna doccia con sistema
termostatico
Thermostatic shower column
Thermostatique colonne de douche



↔ 322CCXN_B1
↑ 312CCXN_B1 0025,6
Kit maniglie Bold per sistema termo-
statico Euphoria o Blaze tre vie
Bold valve handles trim kit for
euphoria and blaze thermostatic
shower unit three ways
Poignées Bold pour système
thermostatique Euphoria ou Blaze -
trois voies



↔ 222CCXN_B1
↑ 212CCXN_B1 0021,9
Kit maniglie Bold per sistema termo-
statico Euphoria o Blaze due vie
Bold valve handles trim kit for
euphoria and blaze thermostatic
shower unit two ways
Poignées Bold pour système
thermostatique Euphoria ou Blaze -
deux voies

FINITURE / FINISHES /
FINITIONS

CC	Cromo Chrome Chrome	1
SS	Nickel Spazzolato Brushed Nickel Nickel Brossé	1,5
CF	Black Crome	1,5
CS	Black Crome Spazzolato Brushed Black Crome Black Crome Brossé	1,8
NP	Nero Opaco Matt Black Noir Mat	1,2
OO	Oro Gold Or	1,5
RS	Oro Rosa Rose Gold Or Rose	1,5
II	Oro Inglese Pale Gold Or Pâle	1,5
IS	Oro Inglese Spazzolato Brushed Pale Gold Or Pâle Brossé	1,8
ON	Ottone Naturale Natural Brass Laiton Naturel	1

Leva rossa
Red lever
Levier rouge

-6 +0,1

Per ogni leva montata
sul prodotto
For each lever mounted
on the product
Pour chaque levier
monté sur le produit

+0,1 +0,1



↔ 122CCXN_B1
↑ 112CCXN_B1 0017,9
Kit maniglie Bold per sistema termo-
statico Euphoria o Blaze una via
Bold valve handles trim kit for
euphoria and blaze thermostatic
shower unit one way
Poignées Bold pour système thermo-
staticque Euphoria ou Blaze - une voie



KB1390 CC



KB2390
 Lavabo Tre fori Bocca Alta
 Three holes washbasin with Tall Spout
 Lavabo 3 trous avec bec long



KB1392
 Lavabo tre fori Bocca Bassa
 Three holes washbasin with Short Spout
 Lavabo 3 trous avec bec court



KB2209
 Lavabo a parete
 monoforo
 Monohole built-in
 basin mixer
 Mitigeur lavabo
 encastré



KB2220
 Bidet
 Bidet mixer
 Mitigeur bidet





KB2306
Lavabo Incasso
Built-in washbasin
Mitigeur lavabo Encastré



KB2306
Lavabo Incasso tre fori
Three hole built-in washbasin
3 trous mitigeur lavabo Encastré



KB1306 CC



KB2312
 Doccia Incasso Tre Vie
 Three Ways Built-in shower
 Mitigeur douche encastré 3 sorties

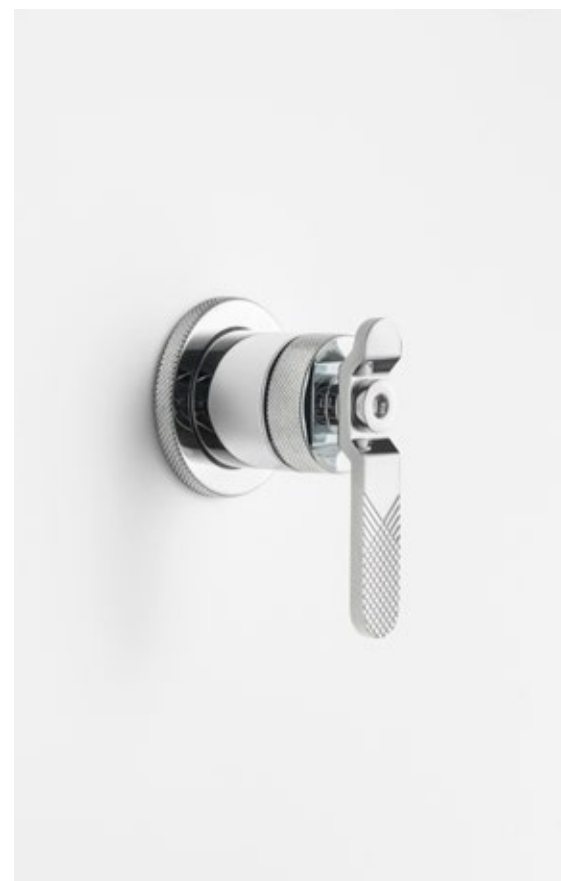

KB2305
 Doccia Incasso
 Built-in shower
 Mitigeur douche encastré

**KB2313**

Doccia incasso due vie con doccetta
 Two ways built-in shower with hand shower
 Mitigeur douche encastré 2 sorties avec douchette à main

**KB1410**

Doccia Incasso Due Vie Tre Fori
 Traditional Built-in shower with Two way diverter
 Douche encastrée avec inverseur

**KB2399**

Colonna doccia con sistema
 termostatico
 Thermostatic shower column
 Thermostatique colonne de douche



A Regolazione flusso d'acqua
Water flow regulation
Régulation débit d'eau

B Valvola termostatica
Thermostatic valve
Valve thermostatique

**KB2396**

Bordo vasca 5 Fori
Five hole deck-mounted bath filler
5 trous baignoire

A
Acqua calda
Hot water
Eau chaude

B
Bocca d'erogazione
Spout
Bec

C
Acqua fredda
Cold water
Eau froide

D
Deviatore
Diverter
Déviateur

E
Doccino
Hand shower
Douchette

**KB1397**

Bordo vasca 4 fori con uscita per
colonna riempimento
Four hole deck-mounted bath filler
with overflow outlet connection
4 trous baignoire avec remplissage
par trop plein

A
Acqua calda
Hot water
Eau chaude

B
Acqua fredda
Cold water
Eau froide

C
Deviatore
Diverter
Déviateur

D
Doccino
Hand shower
Douchette



KB1392 ON



KB1398 ON

Bordo vasca a
parete 5 fori
Five hole wall-moun-
ted bath filler
5 trous baignoire
mural

A
Acqua calda
Hot water
Eau chaude

B
Bocca d'erogazione
Spout
Bec

C
Acqua fredda
Cold water
Eau froide

D
Deviatore
Diverter
Déviateur

E
Doccino
Hand shower
Douchette



KB1399
Bordo vasca da terra
Free-standing Bath Filler mixer
Mitigeur baignoire Free-standing



KB2399
Bordo vasca da terra
Free-standing Bath Filler mixer
Mitigeur baignoire Free-standing



**Deviatore integrato
con sistema PULL
and TURN**
Diverter integrated
with PULL and
TURN system
Déviateur intégré
avec système PULL
AND TURN

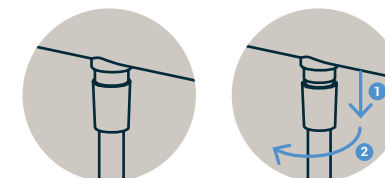



KB1399 CF



KB1392 ON



KB2370
 Lavabo da cucina con bocca girevole
 Kitchen tall Washbasin with rotating sput
 Évier de cuisine avec bec tournant



KB1202 RS

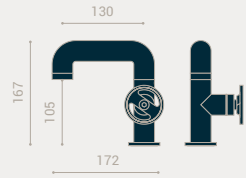

KB1200

1 BAR	2 BAR	3 BAR
3	4.4	4.5

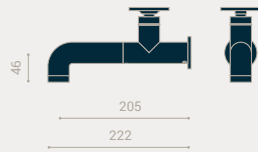

Parte Incasso L 80
Built-In Part H 70
Corps encastré D min 63 - max 73

KB1209

1 BAR	2 BAR	3 BAR
3.3	4.4	4.5

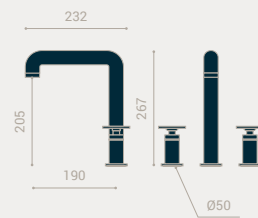

KB1390

1 BAR	2 BAR	3 BAR
3.3	4.4	4.5

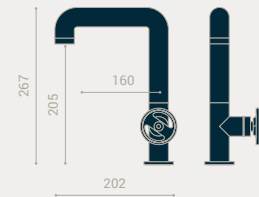

KB1202

1 BAR	2 BAR	3 BAR
3	4.4	4.5

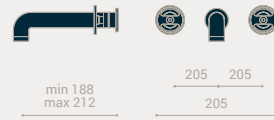

Parte Incasso L 280
Built-In Part H 150
Corps encastré D min 90 - max 80

KB1306

1 BAR	2 BAR	3 BAR
3.3	4.4	4.5

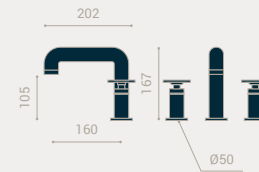

KB1392

1 BAR	2 BAR	3 BAR
3.3	4.4	4.5

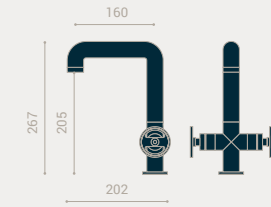

KB1205

1 BAR	2 BAR	3 BAR
3.3	4.4	4.5

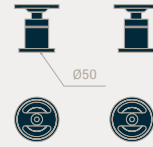

Parte Incasso Min 65
Built-In Part Max 100
Corps encastré G 1/2" F

KB1400

1 BAR	2 BAR	3 BAR
28	40	49.3

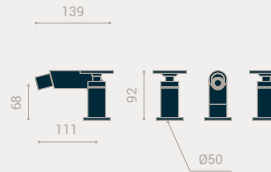

KB1393

1 BAR	2 BAR	3 BAR
3.3	4.4	4.5

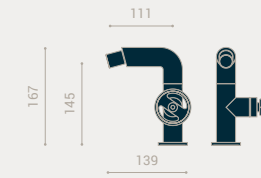

KB1220

1 BAR	2 BAR	3 BAR
5	7	8.6

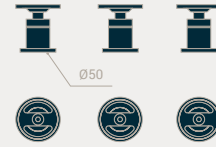

Parte Incasso Min 65
Built-In Part Max 100
Corps encastré G 1/2" F

KB1410

1 BAR	2 BAR	3 BAR
16	22.4	27.4
14.7	20.6	25.3

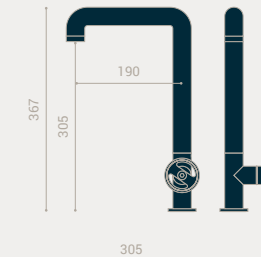

KB1370

1 BAR	2 BAR	3 BAR
3	4.4	4.5

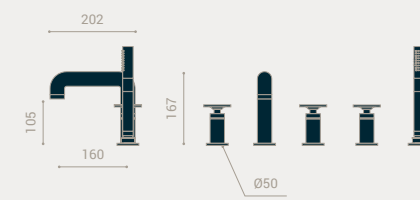

KB1396

	1 BAR	2 BAR	3 BAR
Acqua miscelata / Mixed water	13.6	19.1	23.6
Solo calda / Only hot	9.1	12.9	15.9
Doccetta / Handshower	6.8	10	12.5

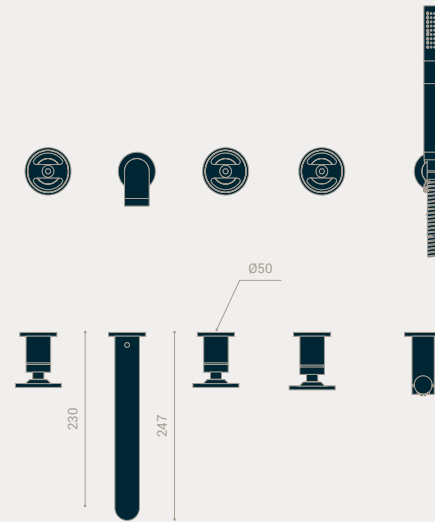

Parte Incasso Min 65
Built-In Part Max 100
Corps encastré G 1/2" F/M

KB1398

	1 BAR	2 BAR	3 BAR
Acqua miscelata / Mixed water	12.3	17.5	21.8
Solo calda / Only hot	9.2	12.9	16
Doccetta / Handshower	8.1	11.5	14

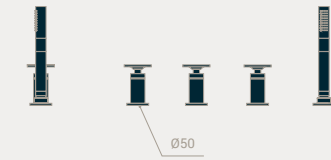

KB1397

	1 BAR	2 BAR	3 BAR
Acqua miscelata / Mixed water	16	23	28
Doccetta / Handshower	6.8	10	12.5

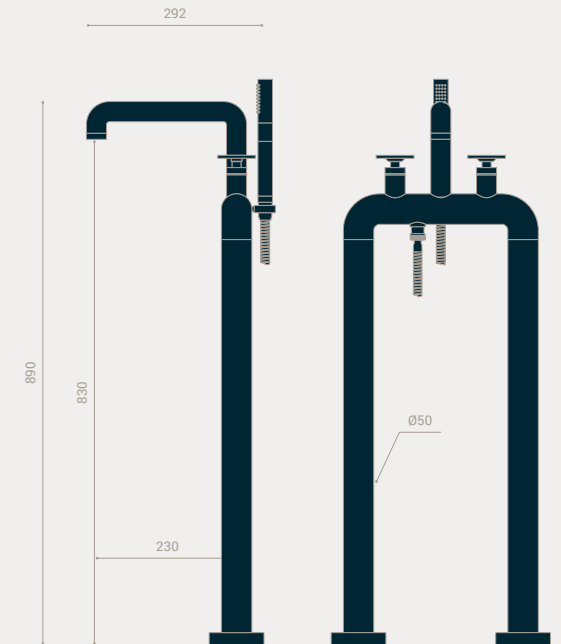

KB1399

	1 BAR	2 BAR	3 BAR
Acqua miscelata / Mixed water	24.5	34.6	43
Solo calda / Only hot	19.8	28.4	34.8
Doccetta / Handshower	7.9	11.4	14.2

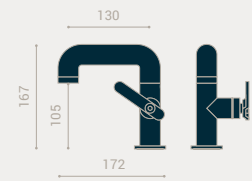

KB2200

1 BAR	2 BAR	3 BAR
3	4.4	4.5

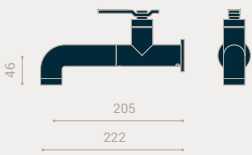

Parte Incasso L 80
Built-In Part H 70
Corps encastré D min 63 - max 73

KB2209

1 BAR	2 BAR	3 BAR
3.3	4.4	4.5

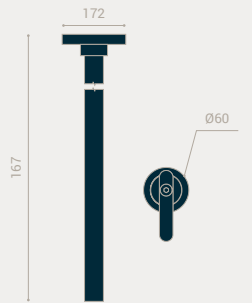

KB2210

1 BAR	2 BAR	3 BAR
4.3	5.2	6.9



Parte Incasso Depth
Built-In Part min 43 - max 61
Corps encastré

KB2300

1 BAR	2 BAR	3 BAR
12.5	17.8	21.9

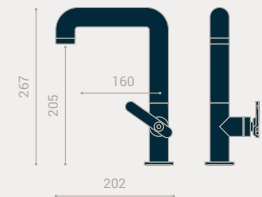

KB2202

1 BAR	2 BAR	3 BAR
3	4.4	4.5

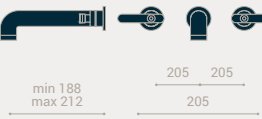

Parte Incasso L 280
Built-In Part H 150
Corps encastré D min 80 - max 90

KB2306

1 BAR	2 BAR	3 BAR
3.3	4.4	4.5

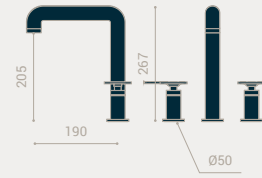

KB2390

1 BAR	2 BAR	3 BAR
3.3	4.4	4.5



Parte Incasso Depth
Built-In Part min 43 - max 61
Corps encastré

KB2305

1 BAR	2 BAR	3 BAR
12.5	17.8	21.9

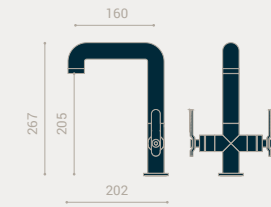

KB2205

1 BAR	2 BAR	3 BAR
3.3	4.4	4.5



Parte Incasso L 230
Built-In Part H 70
Corps encastré D min 70 - max 80

KB2206

1 BAR	2 BAR	3 BAR
3.3	4.4	4.5

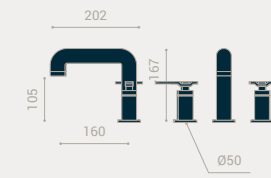

KB2392

1 BAR	2 BAR	3 BAR
3.3	4.4	4.5

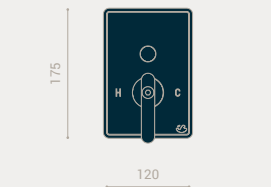

Parte Incasso L 76
Built-In Part H 139
Corps encastré D min 60 - max 70

KB2310

1 BAR	2 BAR	3 BAR
11.6	16.3	20.1

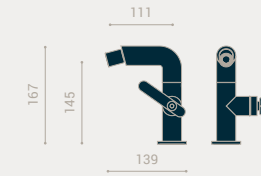

KB2220

1 BAR	2 BAR	3 BAR
5	7	8.6



KB2320

1 BAR	2 BAR	3 BAR
3.3	4.4	4.5

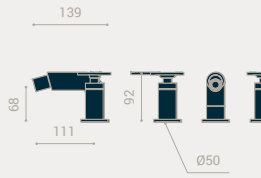

KB2393

1 BAR	2 BAR	3 BAR
3.3	4.4	4.5

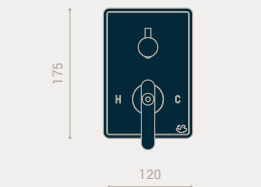

Parte Incasso L 76
Built-In Part H 137
Corps encastré D min 60 - max 70

KB2312

1 BAR	2 BAR	3 BAR
9.5	13.4	16.9

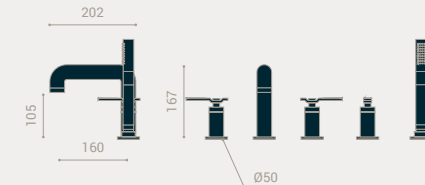

KB2396

	1 BAR	2 BAR	3 BAR
Acqua miscelata / Mixed water	12.3	17.5	21.8
Solo calda / Only hot	9.2	12.9	16
Doccetta / Handshower	8.1	11.5	14



Parte Incasso Min 65
Built-In Part Max 100
Corps encastré G 1/2" F/M

KB2398

	1 BAR	2 BAR	3 BAR
Acqua miscelata / Mixed water	12.3	17.5	21.8
Solo calda / Only hot	9.2	12.9	16
Doccetta / Handshower	8.1	11.5	14

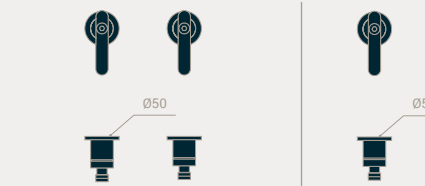

Parte Incasso Min 65
Built-In Part Max 100
Corps encastré G 1/2" F

KB2400

1 BAR	2 BAR	3 BAR
28	40	49.3

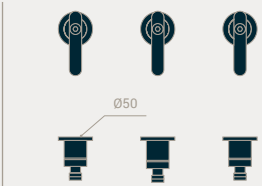

Parte Incasso Min 65
Built-In Part Max 100
Corps encastré G 1/2" F

KB2410

1 BAR	2 BAR	3 BAR	
Uscita principale / Main outlet	16	22.4	27.4
Doccetta / Handshower	14.7	20.6	25.3

KB2399

1 BAR	2 BAR	3 BAR	
Acqua miscelata / Mixed water	24.5	34.6	43
Solo calda / Only hot	19.8	28.4	34.8
Doccetta / Handshower	7.9	11.4	14.2

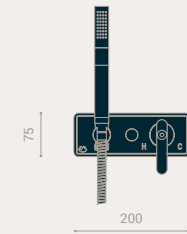
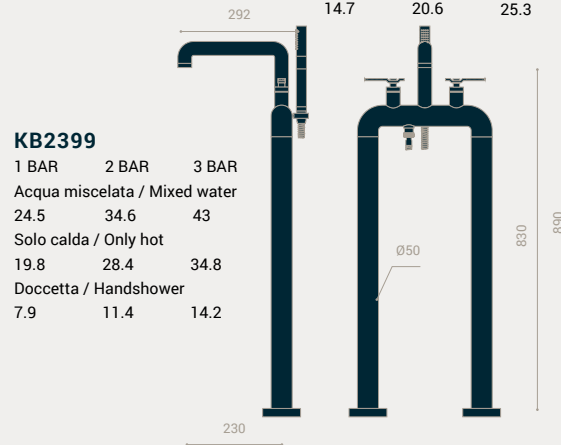

Parte Incasso L 154
Built-In Part H 76
Corps encastré D min 60 - max 65

KB2313

1 BAR	2 BAR	3 BAR
11.6	16.3	20.1



KB2397

1 BAR	2 BAR	3 BAR	
Acqua miscelata / Mixed water	16	23	28
Doccetta / Handshower	6.8	10	12.5

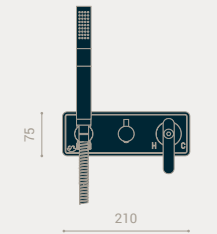

Parte Incasso L 180
Built-In Part H 76
Corps encastré D min 62 - max 67

KB2314

1 BAR	2 BAR	3 BAR
9.5	13.4	16.9

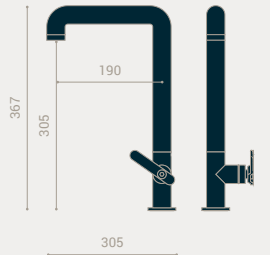

KB2370

1 BAR	2 BAR	3 BAR
3	4.4	4.5

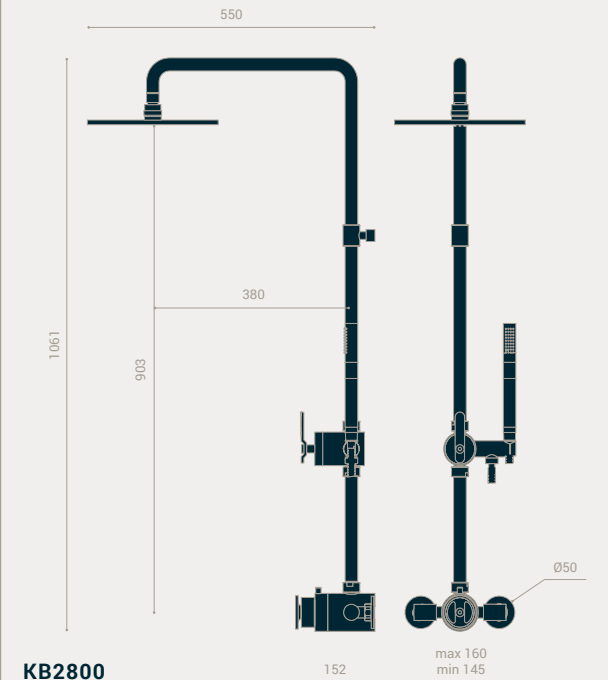

KB2800

1 BAR	2 BAR	3 BAR	
Acqua miscelata / Mixed water	10.7	15	18.5
Doccetta / Handshower	6.7	9.6	11.9

WE ARE
FAMILY

IB RUBINETTI è la storia di una famiglia. Fondata da Elio ed Antonella arricchita di entusiasmo, voglia e amore per il lavoro, tipico delle nostre terre, da Andrea e Davide. Essere parte del mondo IB significa far parte di questa famiglia. Siamo IB RUBINETTI, siamo Elio, Antonella Andrea e Davide Bregoli.

IB RUBINETTI is the story of a family. IB RUBINETTI was founded by Elio and Antonella, enriched with enthusiasm, desire and love for the work, typical of our land, by Andrea and Davide. Being part of the world of IB RUBINETTI means being part of this family. We are IB RUBINETTI, we are Elio, Antonella Andrea and Davide Bregoli.

IB RUBINETTI est l'histoire d'une famille. Fondé par Elio et Antonella et enrichi avec enthousiasme, avec désir et amour pour le travail, typique de notre terre, par Andrea et Davide. Être partie du monde IB signifie faire partie de cette famille. Nous sommes IB RUBINETTI, nous sommes Elio, Antonella, Andrea et Davide Bregoli.

WE ARE
HIGH
QUALITY
MATERIALS

Essere presenti in 5 continenti e affrontare ogni giorno le necessità di ogni singolo paese ci mette nella condizione di non poter accettare nulla che non sia il meglio e proporre il meglio come standard minimo qualitativo. Per questo motivo iB realizza tutti i propri prodotti con materiali privi di zinco e di piombo senza prendere in considerazione se questo sia o non sia necessario in qualsiasi paese.

The need to manage and deal with different needs in many countries in 5 continents puts us in the position of not being able to accept anything but the best quality and offer this as our minimum standard of production. For this reason iB offers all of its products using the material without zinc and leadfree without worrying about the fact that this may or may not be an obligation or less in a country. We think of you.

La nécessité de gérer et de répondre aux différents besoins dans de nombreux pays sur 5 continents nous met dans la position de ne pas être en mesure d'accepter quoi que ce soit, mais la meilleure qualité et offrir ceci comme notre norme minimale de production. Pour cette raison iB propose tous ses produits en utilisant le matériau sans zinc et sans plomb sans se soucier du fait que cela peut être une obligation ou non dans un pays. Nous pensons à vous.



LEAD FREE



ZINC FREE

WE GIVE
SHAPE TO
IDEAS

Da decenni IB RUBINETTI è un punto di riferimento per architetti come Maurizio Duranti, Giulio Iacchetti, Lorenzo Damiani, Remi Theberge, Marco Acerbis, Nadia Mongilardi, Kelly Hoppen, Antonio Gardoni, Federico Castelli... che vedono i loro progetti diventare realtà. IB RUBINETTI ha scelto la strada del design come l'unica possibile, difeso il made in Italy come unica soluzione e crede nel futuro che impara dalla storia.

From decades IB RUBINETTI is a point of reference for architects as Maurizio Duranti, Giulio Iacchetti, Lorenzo Damiani, Remi Theberge, Marco Acerbis, Nadia Mongilardi, Kelly Hoppen, Antonio Gardoni, Federico Castelli... who see their projects become reality. IB RUBINETTI choses design as the only possible way, protects the made in Italy as the only possible option and believes in the future rooted in history.

Pendant des décennies IB RUBINETTI est un point de référence pour les architectes Maurizio Duranti, Giulio Iacchetti, Lorenzo Damiani, Remi Theberge, Marco Acerbis, Nadia Mongilardi, Kelly Hoppen, Antonio Gardoni, Federico Castelli ... et voit leurs projets qui se réalisent. IB RUBINETTI a choisi la route du design comme la seule possible, a défendu le made in Italy comme la seule solution, et croit en l'avenir que apprend de l'histoire.

WE ARE
REAL
MAKERS

Il mondo è diviso in due. C'è chi fa e chi guarda gli altri fare. C'è un'altra divisione: chi fa senza rischio, inseguendo le tendenze e c'è chi fa mettendo in gioco le proprie idee e i propri sogni partendo dalla propria esperienza, dalle proprie origini, ridiscutendo e reinventando ogni volta gli standard. Chi fa tutto questo oggi e lo fa da produttore, reale, toccando l'ottone, trasformando questo o altre materie prime in oggetti innovativi che rappresentano il design italiano, esattamente come fa IB RUBINETTI e pochissimi altri, è un maker. Fedeli al passato, coerenti con il presente e con la propria identità e lanciati verso il futuro.

World is divided into two categories. There are people doing things and people watching. There's an other division: there's who work without risking, following the trends and there's who works bringing into the game his own idea, beginning from his own roots, questioning and changing the standards. Who makes this today and makes it a real manufacturer, touching and transforming brass and the other raw materials into innovative objects that represent the Italian design, just like IB RUBINETTI and few others do, is a maker. Faithful to the past, coherent with the present and their own identity, lean out to the future.

Le monde est partagé en deux. Il y a ceux qui font et ceux qui regardent les autres faire. Il y a une autre division : ceux qui ne risquent, en chassant les tendances, et il y a ceux qui mettent en jeu leurs idées et leurs rêves, à partir de leur propre expérience, de leurs origines, en discutant et en réinventant chaque fois ses standards. Qui fait tout cela aujourd'hui et il le fait en tant que producteur, vrai, en touchant le laiton, tournant ce ou d'autres matières premières en objets innovants qui représentent le design italien, comme il le fait iB Rubineti et peu d'autres, il est un fabricant. Fidèles au passé, en accord avec le présent et avec sa propre identité et lancés vers l'avenir.



Antonio Gardoni e Federico Castelli si distinguono nel panorama internazionale come innovatori dei linguaggi legati all'esperienza dello spazio e come ideatori di oggetti che uniscono forma, funzione e pensiero teorico ai sistemi della comunicazione. Antonio Gardoni dal 1996 collabora con lo studio JUMP di Londra, con Federico Castelli nel 2008 apre una sede satellite dell'AG-studio Italia a Pechino, i loro progetti d'architettura, gli spazi pensati per la moda, il divertimento e il lavoro coniugano innovazione e ricerca estetica. Ogni loro progetto è caratterizzato da un linguaggio unico legato ad un processo che va oltre la cifra stilistica predeterminata. Gardoni e Castelli si dedicano con passione e spirito innovativo ai progetti più vari, dal disegno di interni residenziali agli stand fieristici includendo nel loro lavoro edizioni limitate sperimentali, prodotti industriali all'avanguardia.

Antonio Gardoni and Federico Castelli are internationally recognized innovators in the design language shaping the experience of the space and they are designers of products combining shape, function and conceptual thoughts with communication's tools. Antonio Gardoni from 1996 collaborates with JUMP studios in London and with Federico Castelli opened the satellite office of his Italian "AG-studio" in Beijing, their architectural projects and the spaces designed or fashion brands, entertainment and offices combine innovation and esthetic research. Every project is shaped by a unique language structured with a peculiar design process without aiming to standard predictable solutions. Gardoni and Castelli work with passion and innovative attitude in many different fields, from residential interiors to fair-booth design, together with experimental limited edition of furniture, avant-garde industrial products.

Antonio Gardoni et Federico Castelli se distinguent sur la scène internationale en tant qu'innovateurs de langages liés à l'expérience de l'espace et créateurs d'objets qui combinent la forme, la fonction et la pensée théorique avec les systèmes de communication. Antonio Gardoni de 1996 collabore avec le studio JUMP à Londres, avec Federico Castelli en 2008 ouvre un siège satellite de AG-studio Italia à Pékin, ses projets architecturaux, ses espaces conçus pour la mode, le divertissement et le travail combinent l'innovation et la recherche esthétique. Chacun de leurs projets est caractérisé par un langage unique lié à un processus qui va au-delà de la figure stylistique prédéterminée. Gardoni et Castelli se consacrent avec passion et esprit d'innovation aux projets les plus variés, du design des intérieurs résidentiels aux stands d'exposition, y compris dans leurs travaux des éditions expérimentales limitées, des produits industriels de pointe.

www.federicocastelldesign.com
www.antonio gardoni.com



Tutti i prodotti IB Rubinetti godono di 10 anni di garanzia.

All IB Rubinetti products have a 10-year warranty.

Tous les produits IB ont une garantie de 10 ans.

IB Rubinetterie S.p.A. si riserva la possibilità di modificare in ogni momento i prodotti rappresentati per proprie esigenze tecniche, commerciali o produttive. Le immagini del catalogo rappresentano una indicazione di massima del prodotto ma non sono vincolanti per l'azienda.

IB Rubinetterie S.p.A. reserves the right to modify at any time the products presented in this catalogue. The images of the catalog represent an estimate of the product but are not binding on the company.

IB Rubinetterie S.p.A. se réserve le droit de modifier à tout moment les produits représentés à cause de besoins commerciaux ou de production. Les images dans le catalogue représentent une estimation du produit, mais ne sont pas contraignant pour l'entreprise.

CODICE PRODOTTO
PRODUCT CODE
RÉFÉRENCE PRODUIT

BI 200 CC

Nome serie prodotto
Product series name
Nom de la série

Riferimento tipologia prodotto
Product type reference
Code du type de produit

Codice finitura
Finishing code
Code finition



Per maggiori informazioni sui prodotti
IB RUBINETTI:
For more about IB RUBINETTI'S product on:
Plus sur le produit IB RUBINETTI'S sur:

WWW.IBRUBINETTI.COM

Art Direction and Graphic
Federico Castelli
www.federicocastellidesign.com

Photography
Ottavio Tomasini

Print
Intese Grafiche

Thanks to
Simas





IB RUBINETTERIE s.p.a
via dei Pianotti 3/5
25068 Sarezzo (BS) - Italy -

T. +39 030 802101
F. +39 030 803097
info@ibrubinetterie.com

WWW.IBRUBINETTI.COM

